

# XS XPRESS Scan DIGITAL RADIOGRAPHY SYSTEM



## XPRESS Scan

mobile digital radiography system is intended for single wall or double wall penetration of Ø300–1420 mm pipe welds for pipeline construction or repair.

- No consumables, film processing, or phosphor plates scanning
- No darkroom, no environmental issues
- Image quality class B acc. ISO 19232-5, ISO 10893-7, ISO 17636-2
- Battery operated
- Wireless data transfer
- 3 minutes installation
- External storage under DICOM protocol

Xpress scan digital radiography system provides:

- lower inspection costs by eliminating consumables (X-ray film and film processing chemicals), film processing equipment, film storage facilities;
- compatible with any X-ray source and any crawler;
- inspection results obtained online make it possible to correct welding settings to avoid more defects;
- perfect conditions for image examination (zoom, optimal contrast, image enhancement procedures) and inspection protocol preparation;
- easy to use database.

### LAYOUT OF XPRESS SCAN

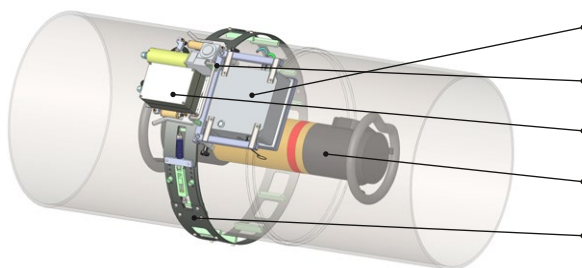

### LAYOUT OF XPRESS SCAN DW

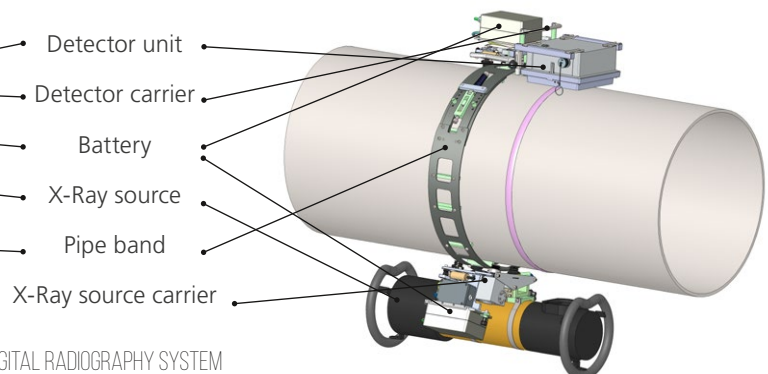

DIGITAL RADIOGRAPHY SYSTEM

Authorized GE RVI representative  
in the Baltic States

**Everest**  
Baltic

Everest Baltic  
Lejaskļīvi, Salas pag., Babītes nov.,  
LV-2105 Latvia

Everestbaltic.lv  
Phone: (+371) 2 911 777 5

# XS XPRESS Scan

## DIGITAL RADIOGRAPHY SYSTEM

### SYSTEM SPECIFICATIONS

	Xpress Scam	Xpress Scan DW
<b>Detector</b>	Resolution: 4 lp/mm (127 µm pixel size) Image size: 145 mm x 145 mm X-ray energy: up to 300 keV Operating temperature: -40°C to +45°C	
<b>Productivity</b>	6 min/weld	16 min/weld Pipe D=1420 mm (21 mm thick)
<b>Image Storage Capacity</b>	200 datafiles (1420 mm weld)	
<b>Data Transfer</b>	Data transfer to the operator's laptop with Wi-Fi, up to 300 m. Data storage: internal memory of the detector; in case of Wi-Fi connection failure, the exposure continues, and the data is secured	
<b>International Protection Code</b>	IP 67	
<b>Power Supply</b>	Power supply/charger: 110-220V AC Detector power supply: 5 Li-Ion batteries (UN 38.3 certified). Battery life 2 hours x 5 batteries = 10 hours X-Ray source carrier: the second set of 5 Li-Ion batteries	
<b>Dimensions and Weight</b>	Transportation case: 860x560x360 mm, 52 kg	Transportation cases: 860x560x360 mm, 52 kg, 860x560x360 mm, 45 kg
<b>Scope of Delivery</b>	Titanium pipe band (Ø1420 mm): Ø1000x130 mm, 9 kg Detector with carrier External battery, 5 or 10 units Transportation case with battery charger & WiFi access point Magnet-mounted WiFi antenna Accessories kit Notebook with DiSoft software Titanium pipe band according to the pipe diameter (12" ... 56" by request) X-Ray source's carrier (for TestXRay DW)	

### XVu SOFTWARE



Real-time X-ray image acquisition. Exposure control, image processing and archiving using XVu software.

X-ray images are stored in DICONDE data format (ASTM E2339-11). Data protection from tempering, compatibility with conventional image formats (tiff16, bmp, jpg), image enhancement. Inspection date, time and GPS coordinates stored in datafile.

Single image built for the whole weld length.



Authorized GE RVI representative  
in the Baltic States

**Everest**  
Baltic

DIGITAL RADIOGRAPHY SYSTEM

Everest Baltic  
Lejaskļivji, Salas pag., Babītes nov.,  
LV-2105 Latvia

Everestbaltic.lv  
Phone: (+371) 2 911 777 5